

# T501

## Comprehensive Condition Monitor

# T501 Advanced Monitoring Solution for Multiple Electrical Assets



Rugged, Most Versatile and Multi-Channel monitoring solution, Capable of monitoring various electrical Assets: Basic Asset Monitoring, Fiber Optic Temperature Monitoring, Partial Discharge, Bushing, OLTC, Load, Power, and more...

T501 is the most advanced monitoring solution designed to monitor multiple electrical assets types with its simple and user-friendly interface. T501 along with customized sensors for specific requirement and software provides condition monitoring of electrical assets by focusing on preventing asset failures and downtime. With our comprehensive monitoring solution, the health of assets can be determined and also maintenance activities can be scheduled. The system along with sensors, monitors, and software (Rugged Connect/ RM EYE) is customizable as per the specifications. The solution can be used for existing (retrofit applications) or new electrical assets.

Our T501 gives state-of-the-art condition monitoring solution for industries with huge electrical infrastructure. It can analyze the data and obtain the predictive diagnostics to detect any serious faults before a major breakdown occurs. T501 is precisely designed to monitor all electrical asset types and to provide a greater visibility into the assets.

## » Features

- Simple visualization & easy to configure
- Equipped with most accurate & advance health assessment analytics
- Range of communication options and protocol support; ethernet redundancy (PRP)
- Highly secure, web server-based visualization and configuration software

## » Applications



**Transformer Monitoring**  
(Oil Filled / Dry type)



**Motors/Generators Monitoring**  
(DOL / VFD)



**Cable Monitoring**  
(EHV / HV / MV)



**Switchgear Monitoring**  
(GIS / AIS / MV Panel)

## » Benefits

- Improved asset reliability
- Accurate predictive analysis
- Access asset data from anywhere
- Increased asset lifetime
- Highest return on investment
- Field upgradable with no device downtime

## » System Architecture

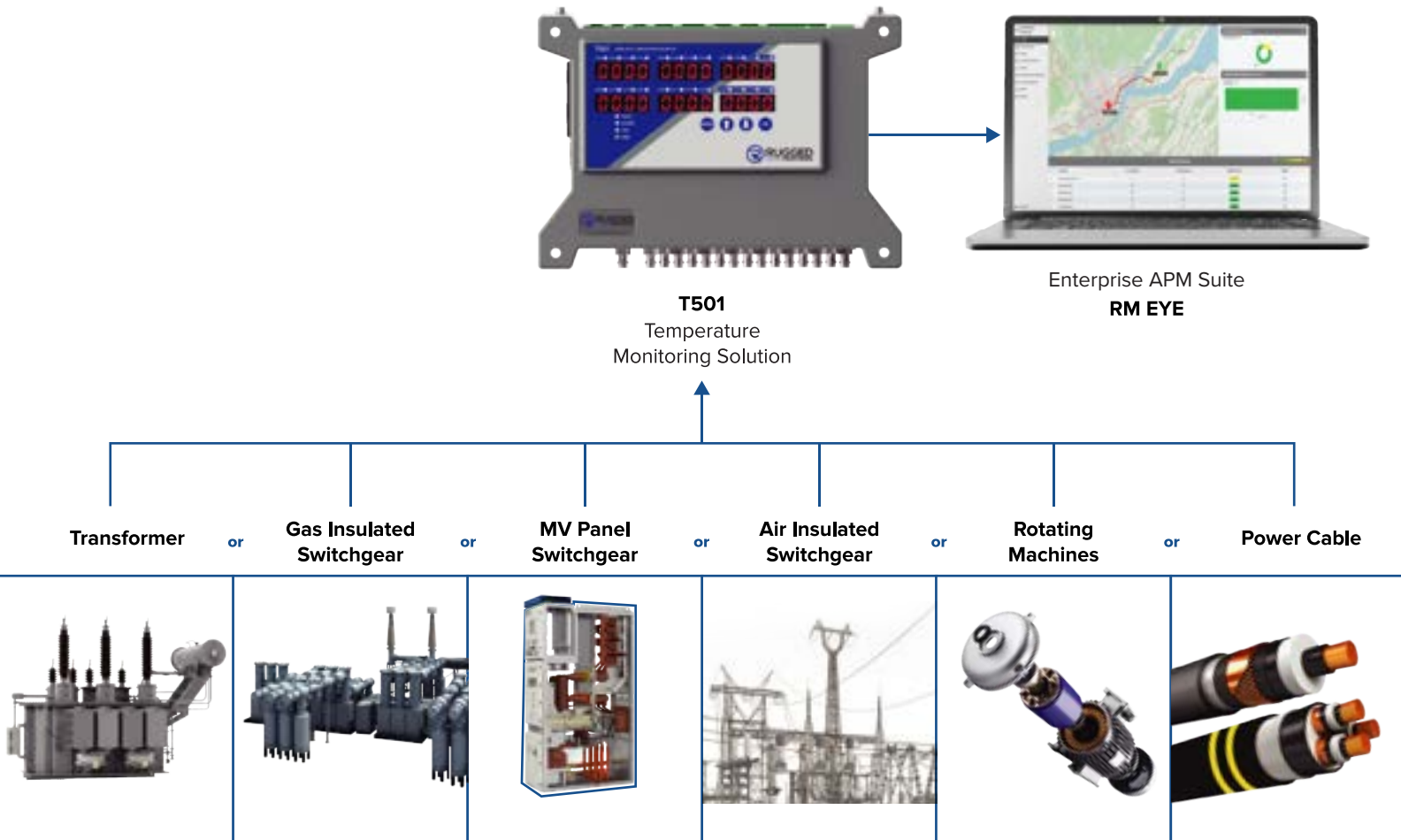

## One Solution for Multi-Site Multi Asset Monitoring

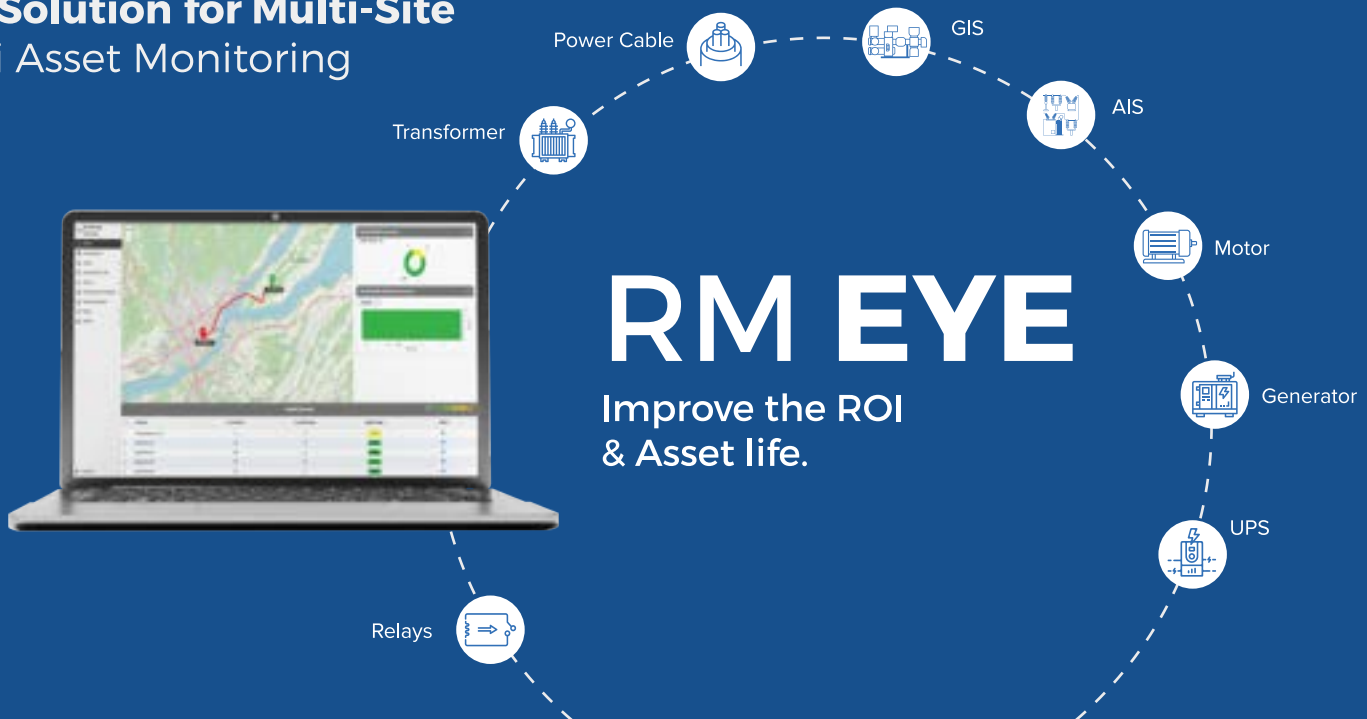

# T501 FEATURES

Comprehensive Features to Meet Market Demand

## Relay Outputs

- 08 x Form C Relay contacts
- NO-C-NC
- Cooling control
- Alerts / Alarms

## Power input

- 24 / 48 Vdc
- Power Supply Unit / Adaptor provided as Accessories (OPTIONAL)

## Analog Outputs

- 04 x User Programmable
- Current Output (4-20mA)
- Voltage Output (0-5V/0-10V)

## Analog / Digital Inputs

- 08 x Configurable Inputs
- RTD (PT-100), Potentiometer
- AC Current (Clamp-On CT), DC current (4-20mA)
- Digital (Dry Contacts)

## Serial Port (R485)

- Data Input/ Output Integration
- Modbus Protocol
- DNP3.0 Protocol
- IEC60870-104 Protocol

## USB Port

- Configuration & Troubleshooting
- Data Export
- MicroSD Card

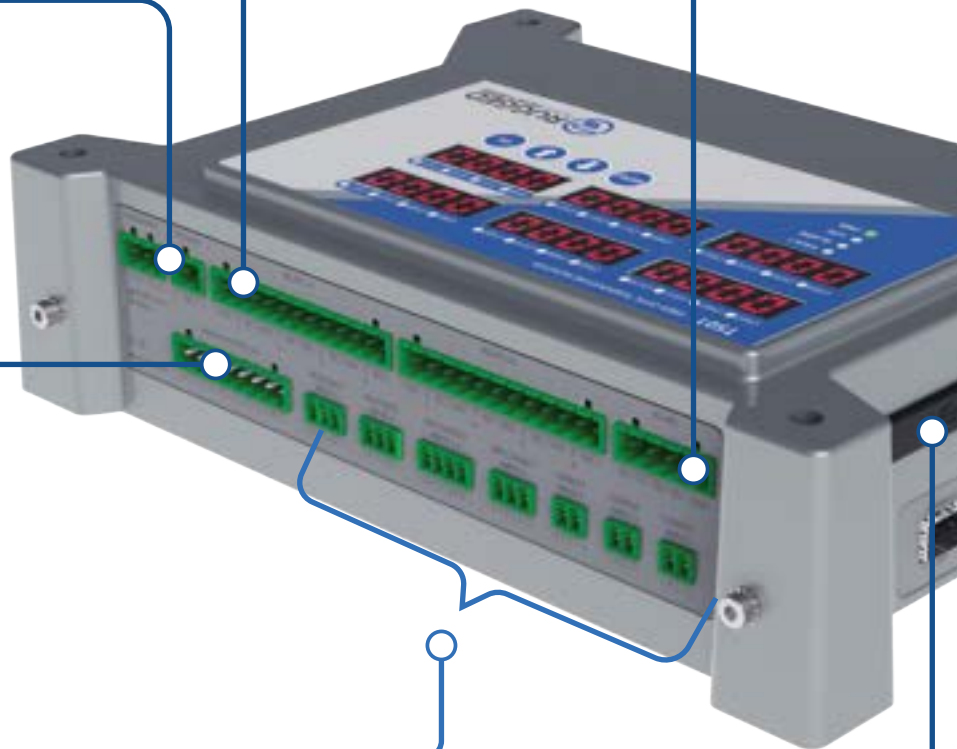



## RUGGED CONNECT SOFTWARE

- Desktop and Web Client
- Remote Configuration
- Advanced Visualization
- Data Logging, Reporting
- Supports Industry Standard Protocols
- Customization available on request
- Secure access to data & Configuration
- Multiple Language Support

### Ethernet Ports

- 02 x configurable Ports (RJ-45/SFP)
- Full Redundancy
- PRP Protocol
- Modbus, DNP3.0, IEC60870-104 and IEC 61850

### LED Indicators

- Power ON/OFF
- System Fault
- Alarm & Log

### Local Display

- Industrial Grade LED
- Current Values of all Parameters

### Fiber Optic Channels

- Up to 24 FO Temperature Inputs
- GaAs based technology
- Built-In Self Test feature
- Higher Signal Strength



## » Technical Specifications

<b>POWER SUPPLY</b>	Input Power Requirement	24/48 VDC $\pm$ 10%
	Power Consumption	20 Watts
<b>ANALOG/DIGITAL INPUT MODULE</b>	# of Input Channels	08/04 Channels
	Input Channel Types	Configurable from a range of input options, RTD, AC/DC current, Potentiometer, Dry contact switch
	Accuracy of Channels	$\pm$ 0.5% full scale input range
	Input Channel Sample Rate	1 Hz
<b>FIBER OPTIC MODULES</b>	Measurement Range	-80 °C to +300 °C (cryogenic 4 °K range optional)
	Resolution	0.1 °C
	Accuracy	$\pm$ 1.0 °C ( $\pm$ 0.2 °C in relative temperature)
	Scan Rate	200 ms / channel ( Optional: Faster scanning rates available)
	Number of Channels	2 to 24 channels
<b>ANALOG OUTPUT MODULE</b>	# of Output Channels	04 Channels
	Output format	4-20 mA or 0-5Vdc / 0-10Vdc (Configurable for any measured / calculated value)
<b>OUTPUT RELAY MODULE</b>	# of Output Channels	08 Form C relays (5A)
	User Programmable	Yes, from Rugged Connect Software or webserver, if present
<b>DATA STORAGE &amp; CONFIGURATION</b>	Data Storage Capacity	4 or 8 GB, Industrial Grade micro-SD, extendable to 2TB
	Logging Rate	User Configurable, 1 sec interval on USB
	System Fault Indication	1 System Fault Relay, with Local LED light
	Config port	USB (to use with Rugged connect windows software)
<b>COMMUNICATION</b>	Serial Communication	01 x RS-485 (RS-232 optional converter)
	Ethernet Communication	02 Ethernet Ports, configurable to RJ-45 or SFP (Gigabit Optical)
	Redundancy	Support PRP Redundancy
	Protocol Supported	Modbus, DNP3.0, IEC60870-104, IEC61850, Other protocols provided on request
<b>EMC TYPE TESTING</b>	Conducted & Radiated Emissions	ICES-003 (2016), CISPR32 (2015), CISPR11 (2015)
	ESD and EM Field Immunity	IEC61000-4-2, C37.90-3, IEC61000-4-3, C37.90.2
	Fast Transient & Surge Immunity	IEC61000-4-4, IEC61000-4-5, C37.90.2
	Magnetic Field Immunity	IEC61000-4-8, IEC61000-4-10
	Immunity from Conducted Disturbances	IEC61000-4-6, IEC61000-4-16
	Ripple, Dips & Damped Oscillatory	IEC61000-4-17, IEC61000-4-18, IEC61000-4-29
	Safety	IEC60255-26 and CE Certified
<b>ENVIRONMENTAL AND MECHANICAL</b>	Operating Temperature	-40 °C to +72 °C
	Operating Humidity	95% Non Condensing
	Storage Temperature	-40 °C to +85 °C
	Dimensions	W 26.7 cm x H 7.2 cm x D 18.7 cm (10.5" x 2.8" x 7.4")
	Weight	App. 1.5 to 2.0 Kg. (based on number of configuration)

# » Product Drawing

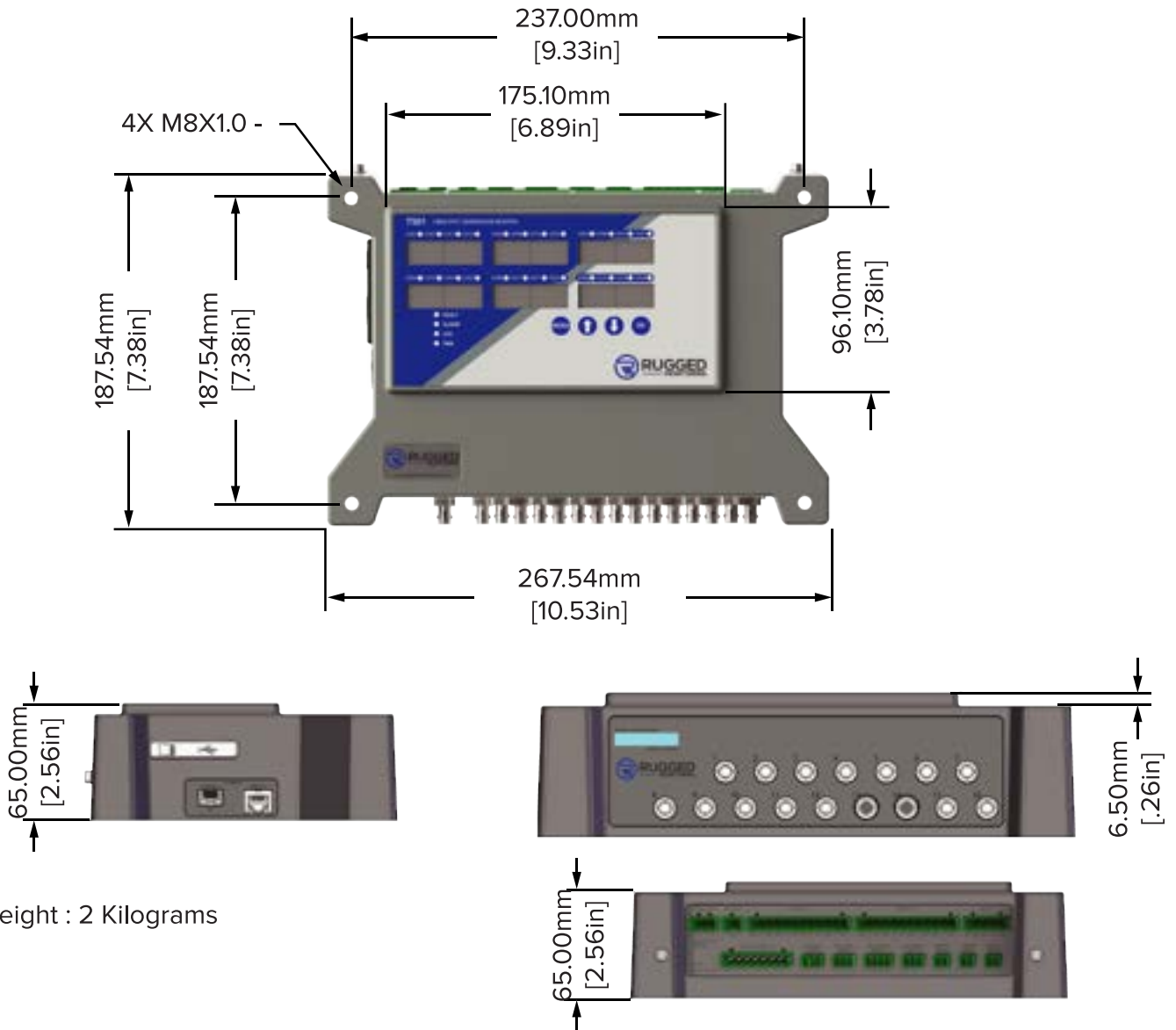

# » Ordering Code

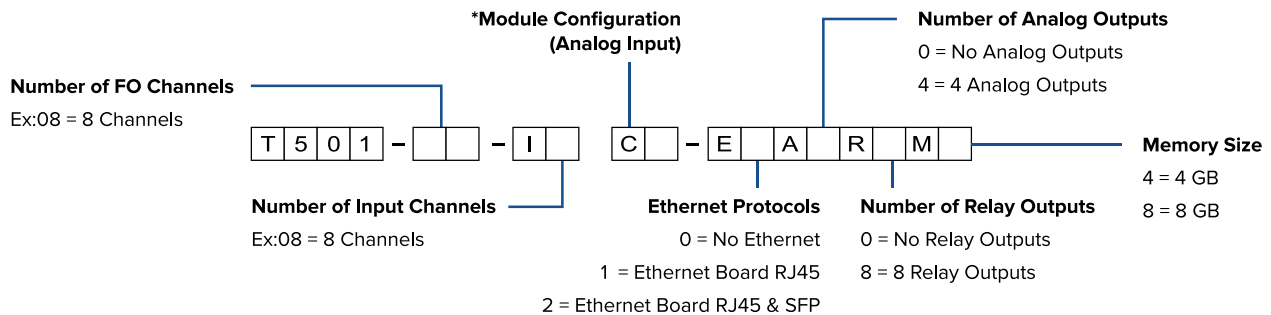

\*For combination of different input channels, contact our sales team

## CERTIFICATIONS



1415 Frank-Carrel, Sulte , 230, Quebec, QC-G1N , 4N7, CANADA

Asia Pacific | China | India | Middle East & Africa | Europe | North America | Latin America

+1-418-767-0111

info@ruggedmonitoring.com

www.ruggedmonitoring.com