



PD201

High Frequency PD Monitoring
Module- Continuous

PD201

Compact & Reliable High-Frequency Partial Discharge Detection



Engineered for real-time PD detection, PD201, is a high-frequency monitoring module for high-voltage assets. It offers insulation assessment, early fault detection, and predictive maintenance with advanced signal processing and automated alerts.

PD201 is a compact, high-performance Partial Discharge (PD) Monitoring Module designed for continuous PD detection and insulation assessment in transformers, switchgear, power cables, and rotating machines. Available in 4 or 8 channel configurations, it enables simultaneous data acquisition without multiplexing and operates within a 0.01 - 50MHz bandwidth at 125 MS/s per channel for precise PD signal capture and classification.

With integrated band-pass filters (5 MHz to 50 MHz) and advanced denoising algorithms, the PD201 ensures accurate PD classification, distinguishing Internal PD, External PD, and Noise. It performs PRPD analysis, PD amplitude measurement, and discharge trend evaluation, delivering real-time insulation health insights.

The PD201 supports IEC 61850, Modbus, TCP/IP, DNP3, and MQTT protocols and integrates seamlessly with SCADA and asset management systems via RS-485, and Ethernet (RJ45). Real-time PD detection and advanced analytics are critical tools for predictive maintenance and high-voltage asset reliability.

» Benefits

- Seamlessly integrates into OEM systems.
- Versatile Mounting options
- Cost Effective PD monitoring
- Seamless Software Integration
- Advanced Data Logging & Analytics
- Customizable for Specific Applications
- High-Precision PD Analysis
- Reliable & Safe Operation

» Features

- Rugged and compact design
- Multi-channel PD monitoring
- Comprehensive PD detection
- High immunity to interference
- Seamless system integration
- Advanced noise management
- Reliable data logging
- Fail safe protection

» Applications

- Transformers
- Switchgear –GIS, AIS, MV Panel
- Power Cables
- Rotating Machines
- Continuous Online PD Monitoring
- HV AC Testing Support
- Multi-Point PD Monitoring

» Technical Specifications

Number of Channels	04 or 08 (Simultaneous acquisition, No Multiplexing)
Sampling Rate	125 MS/s per channel
Acquisition Bandwidth	0.01 - 50MHz
Vertical Resolution	12 - Bit
Noise Elimination -Band Pass Filter -Software Noise Gating	User selectable integrated filters with 5MHz to 50 MHz bandwidth range Advanced denoising algorithms
Data Storage (Memory)	Factory Configured SSD Storage up to 1TB (64GB as standard)
Compatible PD Sensors	Any High Frequency (HF) PD Sensors (Bushing Adaptors, HFCT, TEV, Capacitive Couplers, Acoustic, Ultrasonic etc.)
Synchronization Inputs	2 Inputs (LV and HV) LV: 5V peak HV: 100Vrms - 240Vrms
Serial Port	RS-485 with Modbus RTU
Configuration Port	Ethernet Port for configuration and protocols (RJ45)
Operating Temperature	-30°C to +50°C
Storage Temperature	-40°C to +85°C
Dimensions	4.92"x4.92"x1.89" (125mm x 125mm x 48mm)
Humidity	95% Non Condensing
Power Input	24 - 48 VDC, 50W Maximum
Power Consumption	50W Maximum
Communication Protocols	IEC61850, Modbus, TCP/IP, DNP3, MQTT
Compatible Software	PD Live Webserver, PD Connect, RM EYE

» Product Drawing

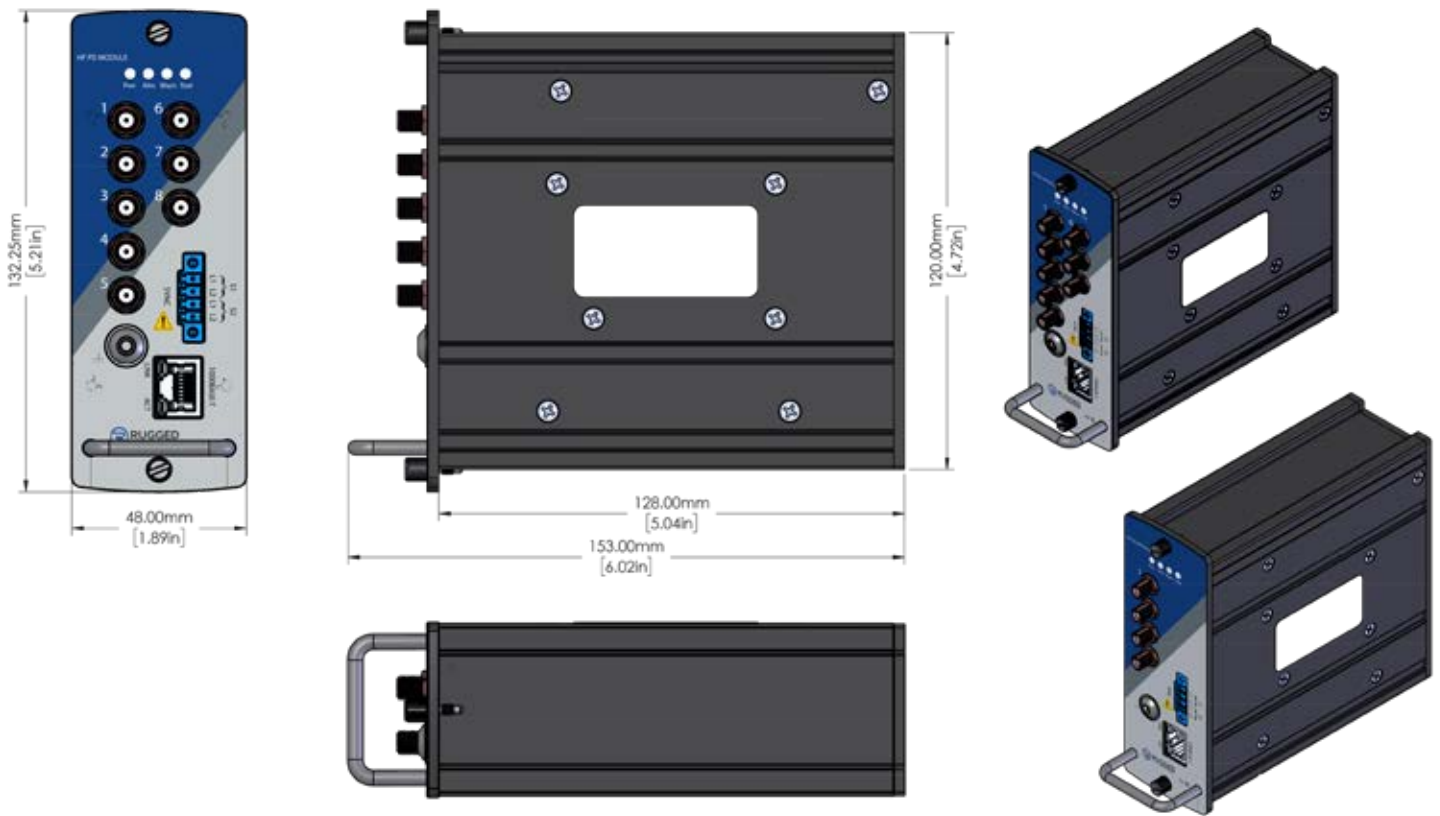

» Ordering Code

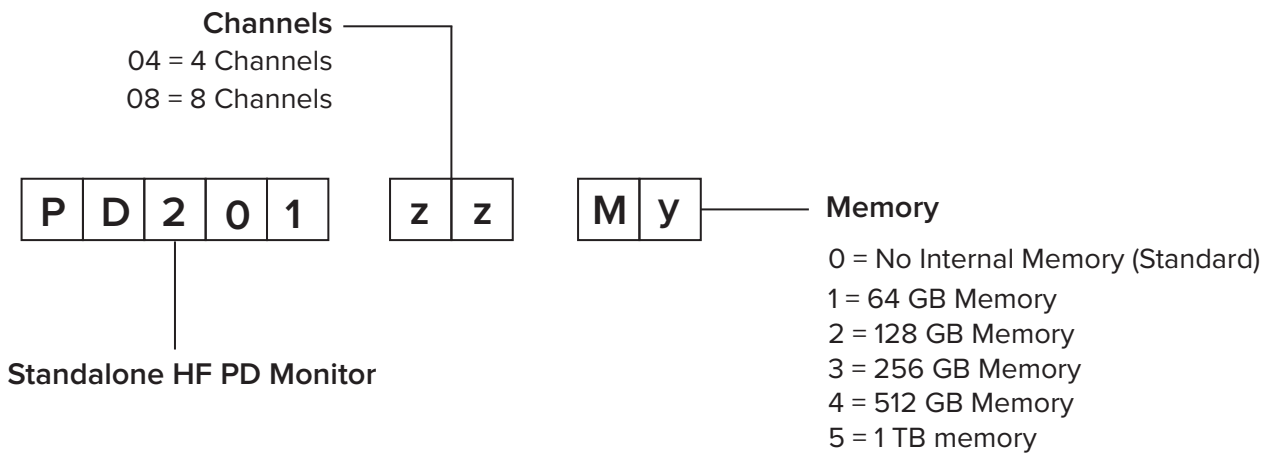

CERTIFICATIONS



Canada

875 Bd. Charest O, Quebec, QC, Canada G1N 2C9

Asia Pacific | China | India | Middle East & Africa | Europe | North America | Latin America

+1-418-767-0111

info@ruggedmonitoring.com

www.ruggedmonitoring.com