

# PD211

Ultra-High Frequency PD Monitoring  
Module-Continuous

# PD211

## Advanced UHF-Based Partial Discharge Monitoring Solution



The Rugged Monitoring PD211 is a compact and durable module for accurate Partial Discharge (PD) monitoring in essential electrical assets, including Transformers, GIS Circuit Breakers, Switchgear - GIS, MV Panel and Power Cables. Engineered for reliability, the PD211 provides effective insulation health monitoring to improve safety and system efficiency.

The PD211 is an advanced Partial Discharge (PD) monitoring module that utilizes Ultra High Frequency (UHF) technology for accurate signal acquisition and analysis. It supports 4 or 8 channels in two configurations, enabling connection with an equal number of UHF PD sensors. The system is compatible with sensors operating within the 300 MHz to 2000 MHz frequency range, ensuring seamless integration across various monitoring setups.

Designed for reliability, the PD211 monitors and analyses UHF signals generated by PD activity in critical electrical assets such as Transformers, GIS Circuit Breakers, Switchgear - GIS, MV Panel and Power Cables. It classifies signals into internal PD, external PD, or noise, delivering precise diagnostics. Internal PD data is stored and processed for advanced analyses, including Phase Resolved Partial Discharge (PRPD) patterns, amplitude, discharge rate, and trend evaluations.

The PD211 features robust communication capabilities. It transmits PD amplitude and discharge rates to third-party systems via Modbus (RTU) through its integrated RS-485 port. PRPD data is stored locally and shared through its communication ports facilitating seamless integration with external systems for comprehensive monitoring and analysis.

## » Features

- Compact design with flexible mounting
- High Sampling Rate
- High PD sensitivity
- Secure SSD storage
- Seamlessly integrates with software
- Simultaneous PD acquisition
- Wide acquisition bandwidth
- User-selectable noise filtering
- Protocol Compatibility

## » Benefits

- Optimized for OEM Integration
- Seamless System Compatibility
- Customizable meet customers specific requirement
- Reliable and Robust Design
- Cost-Effective PD Monitoring
- Advanced Data Logging & Analytics
- Accurate PD detection with noise gating

## » Applications

- Continuous Online PD Monitoring
- Multi-Point Partial Discharge Monitoring.
- GIS Circuit Breakers
- Power Cables
- High Voltage AC testing
- Transformer Monitoring
- Switchgear - GIS, MV Panel

## » Technical Specifications

Number of Channels	04 or 08 (Simultaneous acquisition, No Multiplexing)
Sampling Rate	360 points per cycle
Acquisition Bandwidth	300MHz-2000MHz
PD Sensitivity	-10 dBm to -65 dBm
Noise Elimination	User selectable 4 UHF Band Pass Filters <ol style="list-style-type: none"> <li>1. 440-575 MHz</li> <li>2. 300-575MHz</li> <li>3. 1100-2000MHz</li> <li>4. 300-1100MHz</li> </ol>
Data Storage (Memory)	Factory Configured SSD Storage Upto 1TB (64GB as standard)
Compatible PD Sensors	Any Ultra High Frequency (UHF) PD Sensors with bandwidth 300MHz-2000MHz
Synchronization Inputs	2 Inputs (LV and HV) LV: 5Vpeak 100 Vrms- 240 Vrms
Serial Port	RS-485 with Modbus RTU
Communication Ports	Ethernet Port for configuration and protocols (RJ45)
Operating Temperature	-30°C to +50°C
Storage Temperature	-40°C to +85°C
Dimensions	187.00 mm x 120mm x 48mm
Humidity	95% Non-Condensing
Power Input	24-48 VDC, 50 W Maximum
Compatible Software	PD Live Webserver, PD Connect, RMEYE
Communication Protocols	IEC61850, Modbus,TCP/IP, DNP3, MQTT

## » Product Drawing

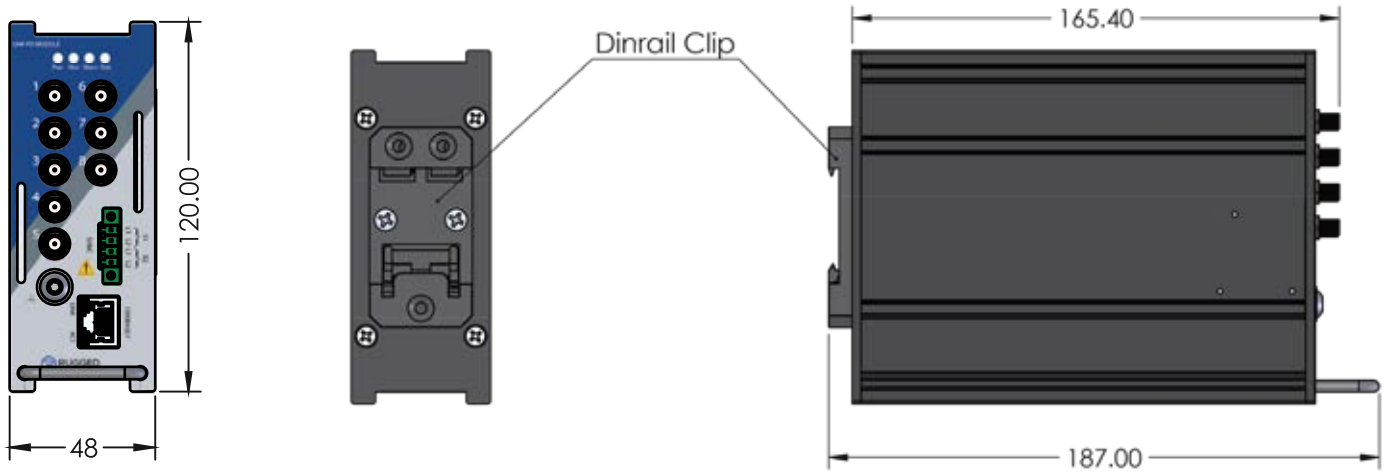

Note: All dimensions are in millimeters (mm)

## » Ordering Code

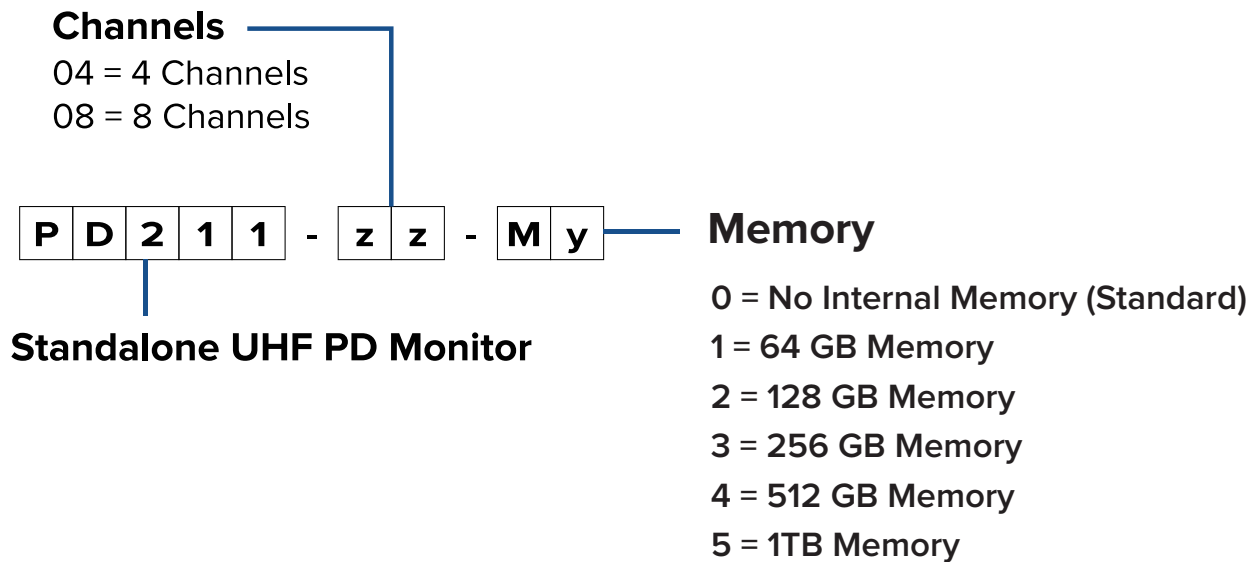

### CERTIFICATIONS



Canada

875 Bd. Charest O, Quebec, QC, Canada G1N 2C9

Asia Pacific | China | India | Middle East & Africa | Europe | North America | Latin America

+1-418-767-0111

info@ruggedmonitoring.com

www.ruggedmonitoring.com