



# UPM601-C

Ultra High Frequency Partial  
Discharge Monitor-Continuous

# UPM601-C

## Advanced UHF PD Monitoring for Continuous Asset Reliability



UPM601-C is an advanced Partial Discharge monitoring system, enabling 24/7 insulation defect detection in high-voltage assets. It also facilitates offline PD measurements during HV AC testing for comprehensive condition assessment and maintenance planning.

UPM601-C is Rugged Monitoring's advanced Partial Discharge (PD) monitoring solution, designed to detect and analyze ultra-high-frequency (UHF) signals in electrical assets. By providing real-time insights into insulation degradation, it enables early fault detection and proactive maintenance, reducing the risk of unexpected failures. With the ability to detect critical defects on-site, UPM601-C is an essential tool for ensuring the reliability and longevity of transformers, switchgear, reactors and power cables.

It features 4 or 8 UHF channels with frequency range from 300 to 2000 MHz, transient over-voltage protection, and 360 Points/Cycle sampling rate, making it highly effective for online PD testing and condition monitoring. It autonomously collects and stores data from multiple sensors, supporting high-voltage (HV) commissioning for both new and retrofit applications. To ensure optimal sensitivity, Rugged Monitoring offers customized sensor design and calibration services that are rigorously tested to meet industry standards.

Housed in a durable polycarbonate resin travel case, the UPM601-C is compact and easy to install, requiring only an external mains supply for operation. Its integration with Rugged Monitoring's RM EYE Enterprise APM Suite allows seamless data transmission, detailed analytics, and AI-driven insights. The system efficiently processes thousands of pulses per second, generating accurate Phase Resolved Partial Discharge (PRPD) graphs to help identify PD types in high-voltage assets.

With advanced noise suppression, onboard amplification, and a robust design built for challenging environments, the UPM601-C ensures precise PD measurements even in high-interference conditions. Paired with RM EYE's intuitive dashboards, customizable alarms, and predictive analytics, it empowers asset managers with the tools to enhance operational efficiency and extend equipment lifespan.

### » Features

- Real-time fault Detection & Analysis
- Transient Over-Voltage Protection
- Software-configurable band-pass Filters
- Autonomous Data Collection & Storage
- Multi-Channel High-Precision Monitoring
- Seamless Integration with Third-Party Systems

### » Benefits

- Enhanced Asset Reliability
- Reduced Downtime & Maintenance Costs
- Highly Accurate & Reliable PD Analysis
- Extended Equipment Lifespan
- Portable & Easy to Deploy
- Improved ROI

## » Applications

- Continuous online PD monitoring.
- Offline PD measurements during high-voltage (HV) AC testing.
- Multi-point PD monitoring
- Power Transformers
- Switchgear- GIS and AIS
- Reactors
- Power Cables

## » Technical Specifications

<b>Sampling Rate</b>	UHF : 360 Points/Cycle
<b>UHF Frequency Range</b>	300MHz - 2000MHz
<b>No. of Channels</b>	4 No's or 8 No's Option available
<b>Sensitivity</b>	-10dBm to -75dBm
<b>Noise Elimination</b>	User selectable 4 UHF Band Pass Filters. <ol style="list-style-type: none"> <li>1. 440-575 MHz</li> <li>2. 300-575 MHz</li> <li>3. 1100-2000 MHz</li> <li>4. 300-1100 MHz</li> </ol>
<b>Communication Protocols</b>	Ethernet Copper-RJ45. Proprietary TCP/IP Modbus, MQTT, IEC61850
<b>Power Rating</b>	50W
<b>IP Rating</b>	IP65
<b>Synchronization</b>	<ol style="list-style-type: none"> <li>1. Internal Raw Power Supply</li> <li>2. External with Rogowski Coil, Electrical Field Sensor</li> <li>3. 110 V VT Signal</li> </ol>
<b>Compatible Sensors</b>	USENS-V, USENS-T, USENS-BT, USENS-B USENS-C, USENS-G, USENS-W
<b>Ambient Temperature</b>	-30°C to +60°C
<b>Storage Temperature</b>	-40°C to +85°C
<b>Dimensions</b>	420.6 mm (L) x 352.5 mm (W) x 153.25 mm (H)
<b>Software</b>	Web based software (PD Live - Default) or Enterprise Level (RMEYE)
<b>Asset Types Monitored</b>	Transformers, Reactors
	Switchgear GIS and AIS
	Power Cables

# » Product Drawing

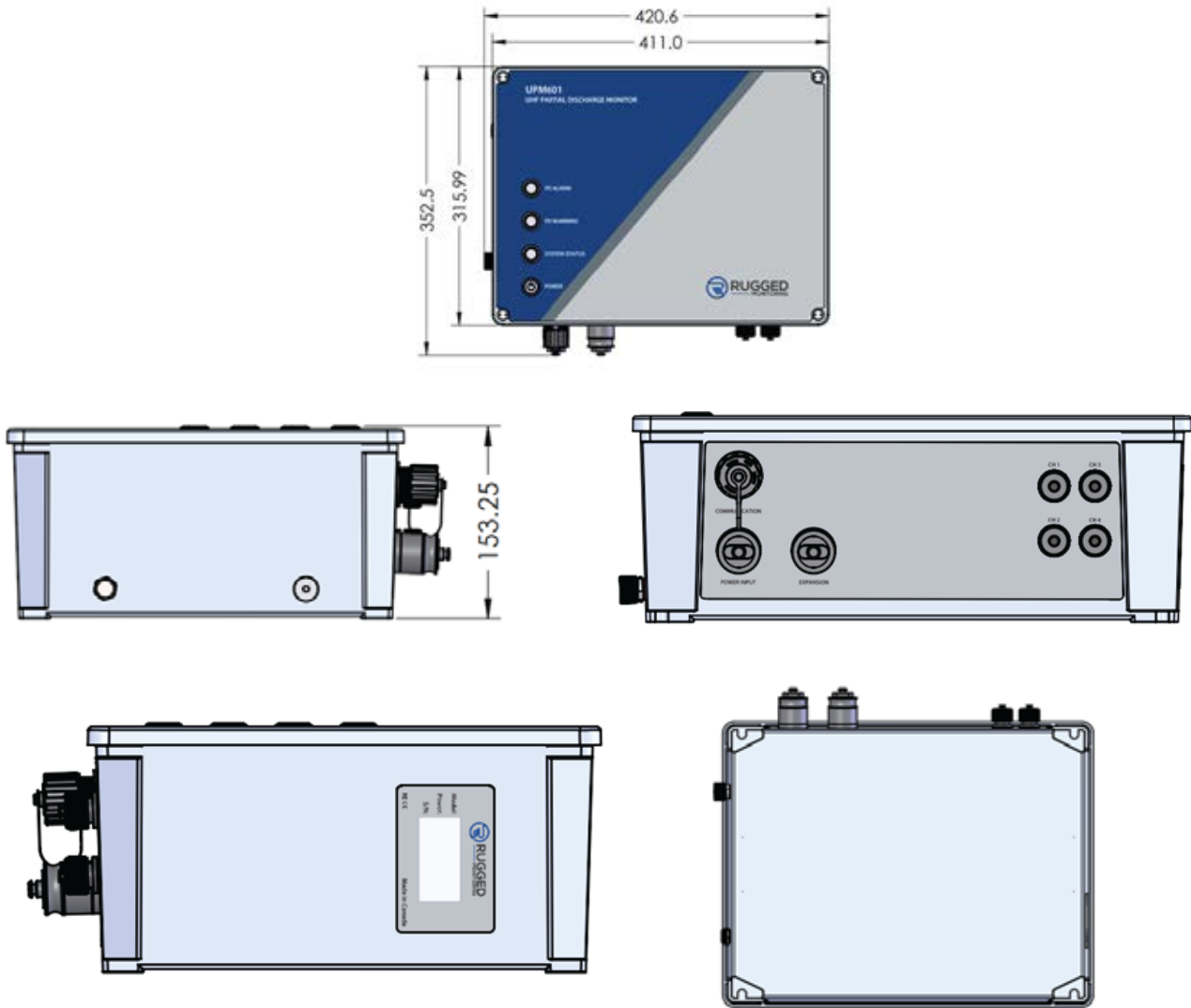

Note: All dimensions are in millimeters (mm)

# » Ordering Code

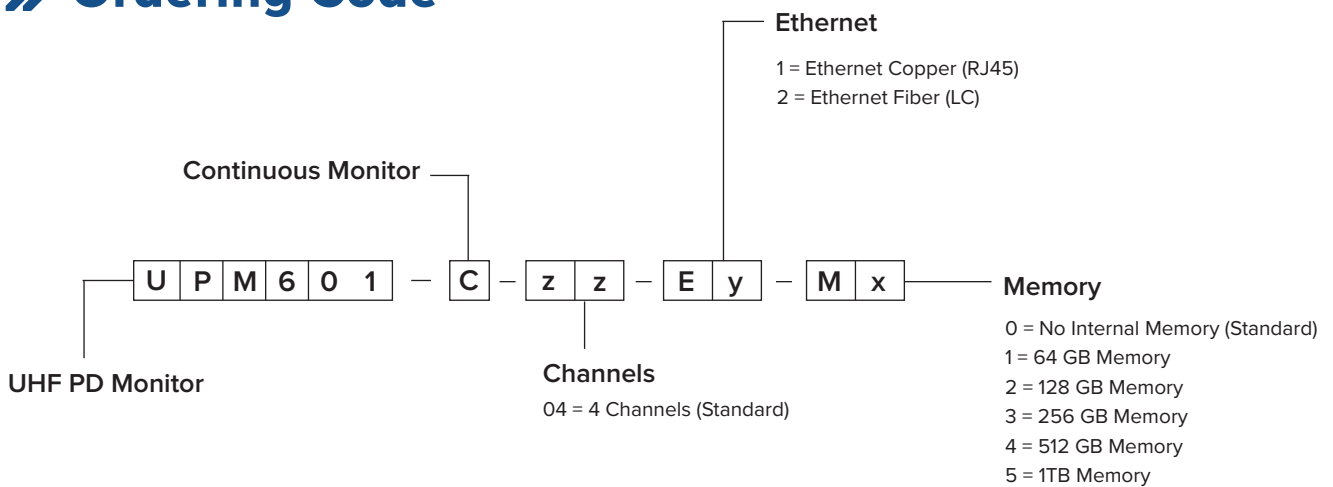

## CERTIFICATIONS



875 Bd. Charest O, Quebec, QC, Canada G1N 2C9

Asia Pacific | China | India | Middle East & Africa | Europe | North America | Latin America

+1-418-767-0111

info@ruggedmonitoring.com

www.ruggedmonitoring.com