



GSENS2

ONLINE OIL ANALYSIS

GSENS2 Online Oil Analysis



Provides highly accurate information about the abnormalities in the oil and to ensure the best health condition in transformers.

Maintenance of Transformer has evolved over the years from a necessary item of expenditure to a strategic tool in the management of electrical transmission and distribution networks.

Determination of fault gases, moisture in oil and oil temperature of transformer insulating oil in the gas concentration is very important. By accurately monitoring the condition of the oil, any sudden faults can be identified, and outages can potentially be avoided. Leading to an efficient approach to maintenance and the optimum intervals can be determined for replacement.

Based on the core technology GSENS2 is a lower cost alternative, monitoring key gases: Hydrogen, Carbon Monoxide (in ppm) plus moisture in oil (%RH & ppm) as an option and Oil Temperature. The measurement of these gases allows the user to detect a wide range of developing faults including arcing.

We at Rugged Monitoring are motivated to provide innovative and exceptional quality products, our vision remains focused on meeting customer requirements while anticipating and exceeding the needs of a continuously changing dynamic market.

» Benefits

- Extended transformer life
- Minimize the need for internal inspections
- Simple and quick installation
- Less maintenance
- Mitigate the Risk and Potential for any catastrophic failures
- Easy to mount on the operating transformer without any operational interruption
- Advanced software with intuitive operation

» Features

- Provides the ability to identify fault type
- Detection of potential failures before any fault occurs
- Prolongation of service intervals and with this, enhancement of working hours
- No calibration required
- Early indication of incipient faults
- Establish baseline data for evaluation

» Measurement

Application	Determination of the gas concentration of fault gases as well as moisture in oil and oil temperature of mineral-based transformer insulating oil in accordance with IEC 60296:2012 /ASTM D3487-09				
Measured Values	H2	CO	Humidity		Oil temperature
			relative display can be switched	absolute display can be switched	
Lower Detection Limit	15 ppm	25 ppm	3% RH	5 ppm	-20°C
Upper Detection Limit	2000 ppm	2000 ppm	90% RH	2000 ppm	+115 °C
Measuring Accuracy	±10 %1,2 or 3 ±20 ppm	±15 %1,2 or 3 ±20 ppm	±2 %RH5	±2 %4	±1 °C
Repetition Accuracy	±5 %2 or 3 ±10 ppm	±5 %2 or 3 ±10 ppm	±1 %RH	±1 %4	±1 °C
Sensor resolution	1 ppm	1 ppm	1 % RH	NA	1 °C

» Conditions of use

Locations of use	Indoors and outdoors, all climate zones
Installation altitude	Up to 4,000 m above MSL
Offshore	Optional
Mounting location	Directly on the transformer tank or in the oil closed circuit cooling pipe; installation horizontal
Ambient temperature during operation ⁶	-40°C to +60 °C
Oil temperature during operation ^{6,7}	-20°C to +115 °C
DGA measuring range with respect to the ambient temperature ⁶	-20°C to +60 °C
DGA measuring range with respect to the oil temperature ^{6,7}	+10°C to +90 °C
Ambient humidity	0 to 100 %RH
Ambient temperature storage/transport	-40°C to +80 °C

⁶ Please contact RM to check the use in case of extreme conditions

⁷ At the point of measurement

» Device Properties

Mechanical connection	Via ball valve and configurable flange DN50 or DN80 (several flanges available); with safety chain for safe installation and removal
Measuring pipe length	Two different lengths for optimum measuring conditions. Short measuring pipe: 285 mm Long measuring pipe: 507 mm
Oil extraction connection	Luer lock socket on the device. adapter set for safe and clean oil extraction included in the scope of delivery
Operation	Optional VFD display (suitable for use in daylight) with 3 operating keys for displaying measured values and messages as well as for calling up parameters
Materials used	Stainless steel and aluminum. all external parts and parts in contact with oil are weather resistant, resistant to transformer oil and UV-resistant
Gasket material	FPM (VitonR)
Available colors (terminal box)	RAL 7033 RAL 7038

» GSENS2 – Oil Analysis

TECHNICAL DATA	Degree of protection	IP 66
	Dimensions	435 / 657 x 218 x 264 mm (version with short / long measuring pipe)
	Device weight	Version with short measuring pipe: approx. 12 kg Version with long measuring pipe: approx. 14 kg (Without ball valve / flange / safety chain)
	Ball valve weight	Approx. 6 kg (including flange and safety chain)
ELECTRICAL CONNECTION	Voltage Supply	95V AC to 280VAC, 50/60 Hz or 95 to 280V DC (protected against polarity reversal)
	Power Consumption	< 13 W
	Over Voltage Category	III
	Connection Terminals	Voltage supply, relays and analog outputs: 2.5 mm ² , AWG 14
	Cable Gland	3 x M20 x 1.5 or 3 x 1/2" NPT; 8 mm to 15 mm lead diameter
INTERFACES	Relay Outputs	4 freely configurable signaling relays (1 changeover contact each) for warning and alarm messages and for maintenance messages from the device-internal monitoring. 1 signaling relay for safety messages (e.g., loss of voltage) Contact current capacity: 250 V AC / 5 A; max. 400 V AC, cos φ = 1 at 85 °C; 30 V DC / 5 A to 300 V DC / 0.25 A
	Analog outputs	Passive, signal tolerance 0.03 mA, load resistance max. 700 Ω at 24 V DC GSENSE DGA 200: 2 configurable outputs, 4mA to 20 mA
	Service interface	5-pole socket (Molex) for communication via Modbus RTU and parameterization via MSET parameterization software
	Delivery	On USB stick, included in the GSENSE2 scope of delivery
PARAMETERIZATION SOFTWARE	Operating system	Microsoft Windows 7 8 and up
	Measured value display and evaluation	Display of the current measured values and device information. Event database with time stamp (date and time); graphic display and evaluation of the temporal progression of the measured values. Export of the measured values (CSV file) or settings of a protocol (PDF file)
	Parameterization	Configuration of the parameters for commissioning, communication, and ongoing operation
	Adjustment	Setting the time stamp of the oil sample extraction. Entry of the reference values in accordance with the laboratory report
	Service	Reading out the internal device service database for further analysis by RM experts
	MECHANICAL TESTS	Vibration
Earthquake		2Hz to 10 Hz, 22.5 mm, 1 h (IEC 60068-2-57)
Shock		10 g, 10 ms (IEC 60068-2-27)

» GSENS2 – Oil Analysis

TECHNICAL DATA	Degree of protection	IP 66
	Dimensions	435 / 657 x 218 x 264 mm (version with short / long measuring pipe)
	Device weight	Version with short measuring pipe: approx. 12 kg Version with long measuring pipe: approx. 14 kg (Without ball valve / flange / safety chain)
	Ball valve weight	Approx. 6 kg (including flange and safety chain)
ELECTRICAL CONNECTION	Voltage Supply	95V AC to 280VAC, 50/60 Hz or 95 to 280V DC (protected against polarity reversal)
	Power Consumption	< 13 W
	Over Voltage Category	III
	Connection Terminals	Voltage supply, relays and analog outputs: 2.5 mm ² , AWG 14
	Cable Gland	3 x M20 x 1.5 or 3 x 1/2" NPT; 8 mm to 15 mm lead diameter
INTERFACES	Relay Outputs	4 freely configurable signaling relays (1 changeover contact each) for warning and alarm messages and for maintenance messages from the device-internal monitoring. 1 signaling relay for safety messages (e.g., loss of voltage) Contact current capacity: 250 V AC / 5 A; max. 400 V AC, cos φ = 1 at 85 °C; 30 V DC / 5 A to 300 V DC / 0.25 A
	Analog outputs	Passive, signal tolerance 0.03 mA, load resistance max. 700 Ω at 24 V DC GSENSE DGA 200: 2 configurable outputs, 4mA to 20 mA
	Service interface	5-pole socket (Molex) for communication via Modbus RTU and parameterization via MSET parameterization software
	Delivery	On USB stick, included in the GSENSE2 scope of delivery
PARAMETERIZATION SOFTWARE	Operating system	Microsoft Windows 7 8 and up
	Measured value display and evaluation	Display of the current measured values and device information. Event database with time stamp (date and time); graphic display and evaluation of the temporal progression of the measured values. Export of the measured values (CSV file) or settings of a protocol (PDF file)
	Parameterization	Configuration of the parameters for commissioning, communication, and ongoing operation
	Adjustment	Setting the time stamp of the oil sample extraction. Entry of the reference values in accordance with the laboratory report
	Service	Reading out the internal device service database for further analysis by RM experts
	Service	Reading out the internal device service database for further analysis by RM experts
MECHANICAL TESTS	Vibration	10Hz to 150 Hz at 2 g, 2 h (IEC 60068-2-6)
	Earthquake	2Hz to 10 Hz, 22.5 mm, 1 h (IEC 60068-2-57)
	Shock	10 g, 10 ms (IEC 60068-2-27)

» GSENS2 – FLANGES DIMENSIONS

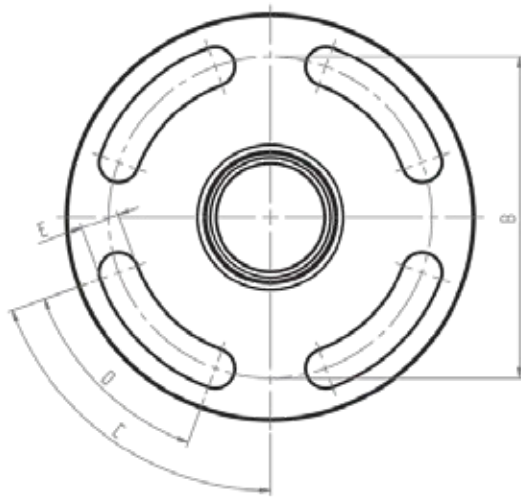

Dimensions see page 7

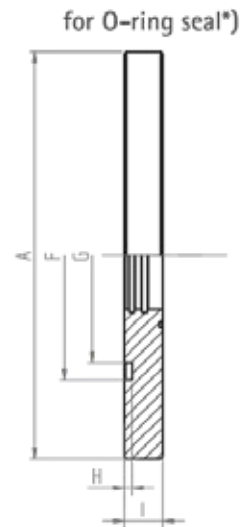

*) O-ring seal included in scope of delivery

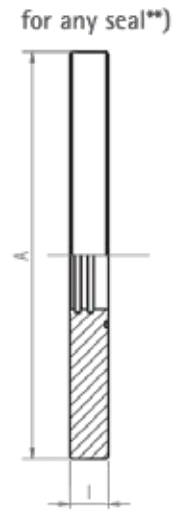

**) No seal in scope of delivery

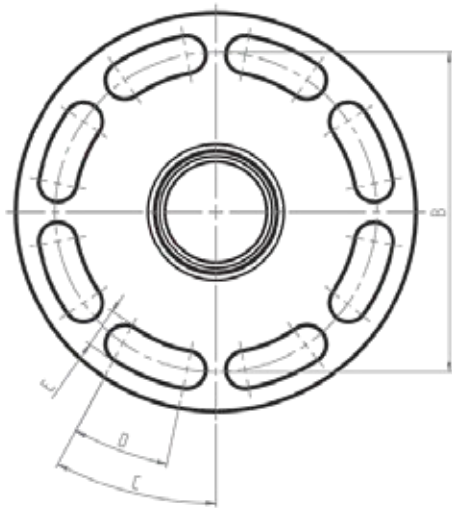

Dimensions see page 7

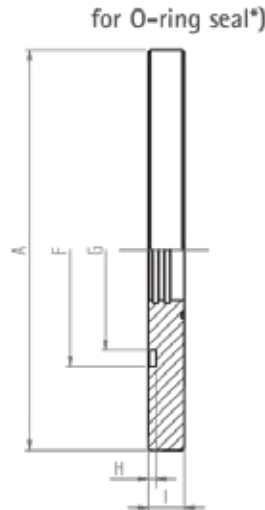

*) O-ring seal included in scope of delivery

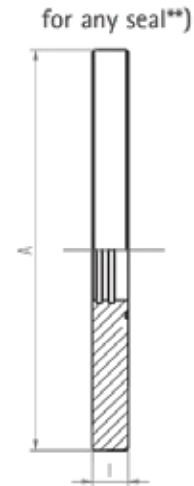

**) No seal in scope of delivery

Dimension Table

Flange Design	DN50 PN6	DN50 PN16	DN50 PN16	DN80 PN16	DN80 PN16
A	Ø 140 [5.51"]	Ø 165 [6.50"]	Ø 165 [6.50"]	Ø 200 [7.87"]	Ø 200 [7.87"]
B	Ø 110 [4.33"]	Ø 125 [4.92"]	Ø 125 [4.92"]	Ø 160 [6.30"]	Ø 160 [6.30"]
C	70°	70°	70°	34.5°	34.5°
D	4 x 50°	4 x 50°	4 x 50°	8 x 24°	8 x 24°
E	Ø 13 [0.51"]	Ø 18 [0.71"]	Ø 18 [0.71"]	Ø 18 [0.71"]	Ø 18 [0.71"]
F	Ø 81 [3.19"]	-	Ø 81 [3.19"]	-	Ø 116.2 [4.57"]
G	Ø 65 [2.56"]	-	Ø 65 [2.56"]	-	Ø 65 [2.56"]
H	3 [0.12"]	-	3 [0.12"]	-	3.9 [0.15"]
I	12 [0.47"]	18 [0.71"]	18 [0.71"]	18 [0.71"]	18 [0.71"]
O-ring seal di x da x t	O-Ring 67mm x 79mm x 4mm 2.64" x 3.11" x 0.16"	for any seal (no seal in scope of delivery)	O-Ring 67mm x 79mm x 4mm 2.64" x 3.11" x 0.16"	for any seal (no seal in scope of delivery)	O-Ring ID100 x O 6 3.9" x 0.24"

» Flange Seals

O-ring for DN50/PN6/16

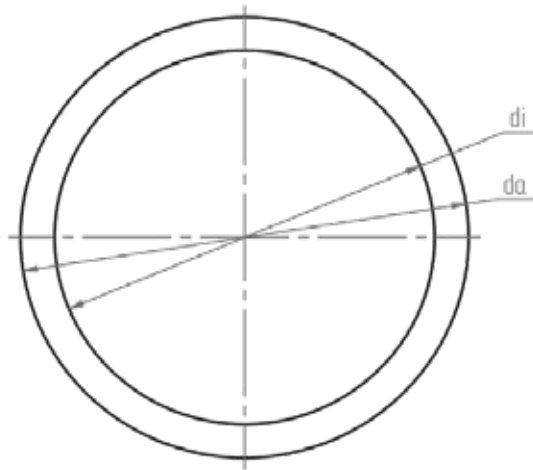

O-ring for DN80/PN16

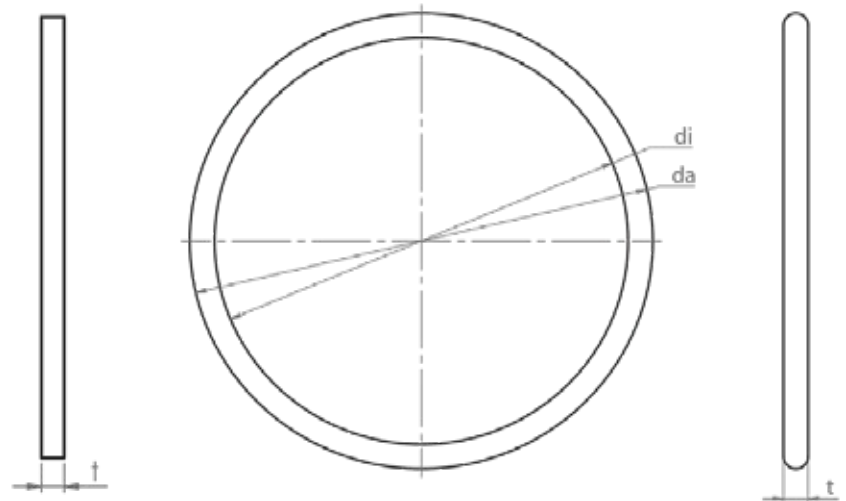

TECHNICAL DATA	Supply voltage	24 V DC
	Power consumption	15 W
	Mounting	On DIN rail
	Ambient conditions during operation	Ambient temperature for horizontal installation position: -25°C to $+70^{\circ}\text{C}$ Relative operating humidity: 10 to 95 % non-condensing Air pressure and altitude: up to 2,000 m above sea level
	Contamination level	2
	Protection Class	II
	Degree of protection	IP 20
	Mounting Orientation	Horizontal
	Ambient conditions for transport storage	Temperature: -40°C to $+85^{\circ}\text{C}$ Relative humidity: 10 % to 95 % non-condensing Air pressure: corresponds to 4,500 m above sea level
	Dimensions and weight	Please refer the diagram for Dimensions Weight: approx. 0.8 kg
CHARACTERISTIC DATA	Communication	Ethernet with 3 Ports, 2 separate networks: 2 x RJ45 (for protocol converter parameterization) 1 x RJ45 (for SCADA)
	Protocols	DNP 3.0 via Ethernet; Modbus TCP; IEC 61850-8-1 MMS (optional)
OPTIONS	Wide range power supply unit	Input 100 V AC to 240 V AC 50/60 Hz ($\pm 10\%$) 110 VDC to 300 VDC (-20% to $+25\%$) Output 24 V DC / 80 W Temperature range -25°C to $+70^{\circ}\text{C}$ Degree of protection IP 20 Dimensions W x H x D 32 x 124 x 102 mm

» PROTOCOL CONVERTER DIMENSIONS

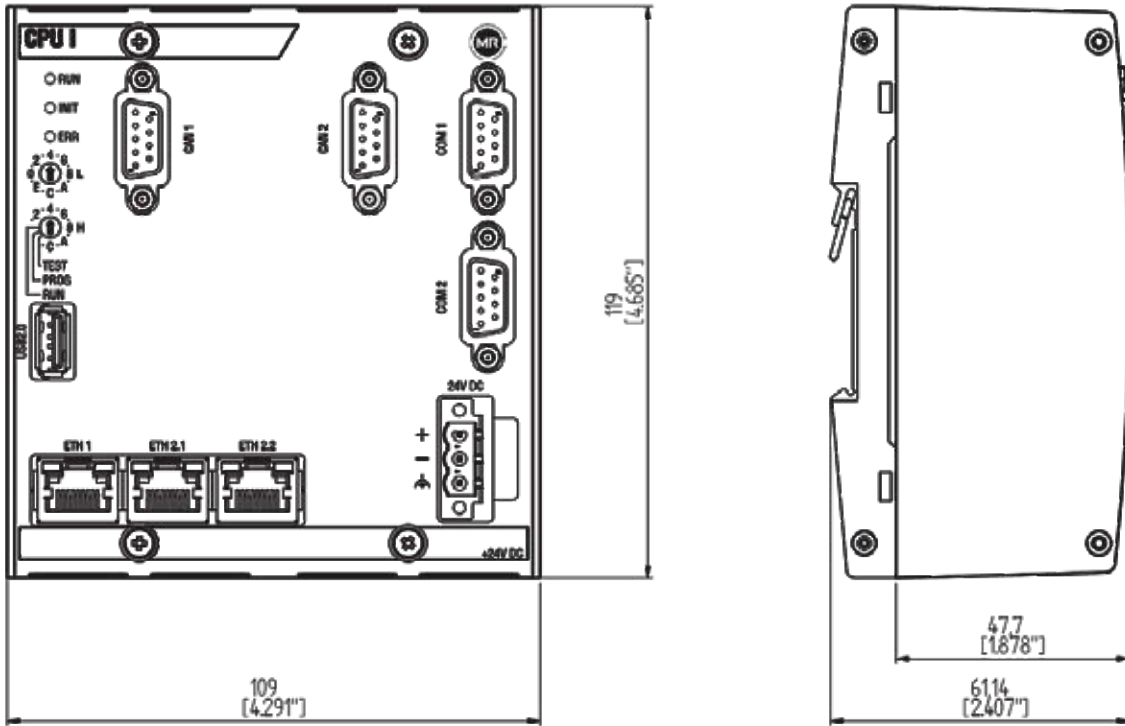

» WIDE RANGE POWER SUPPLY UNIT (OPTIONAL) DIMENSIONS

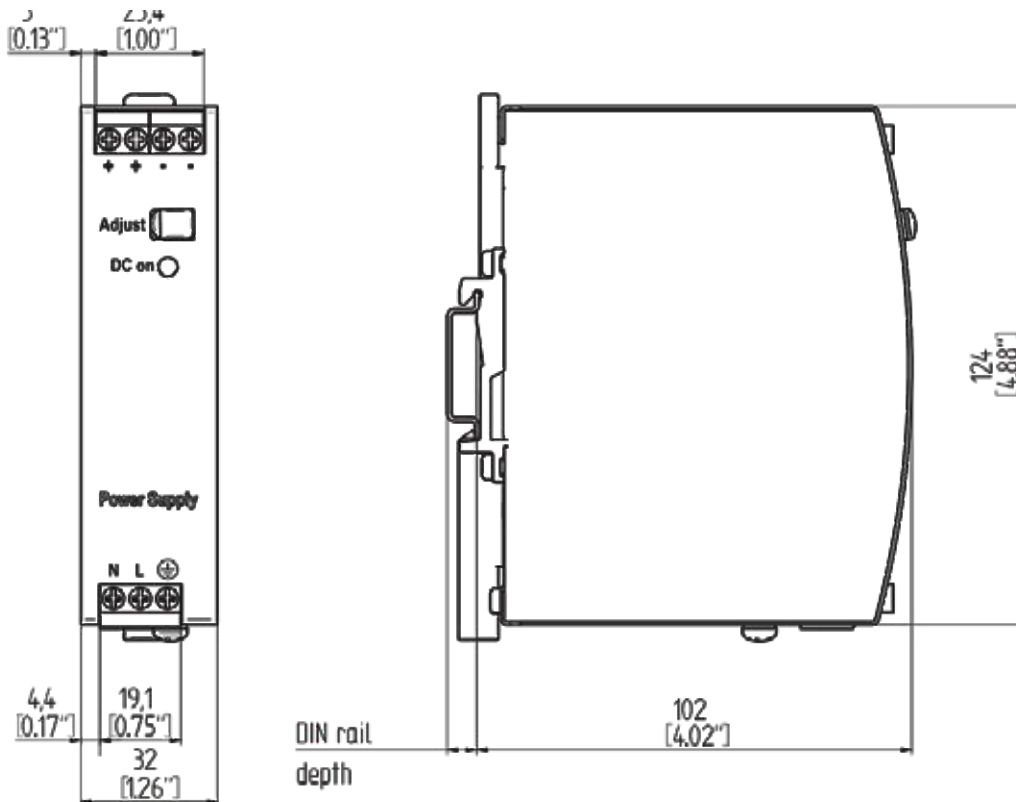

TD4001325/08 EN

CERTIFICATIONS



Canada

875 Bd. Charest O, Quebec, QC, Canada G1N 2C9

Asia Pacific | China | India | Middle East & Africa | Europe | North America | Latin America

+1-418-767-0111

info@ruggedmonitoring.com

www.ruggedmonitoring.com